

LUBRICATION ORDER

LO 10-3930-633-12

10 February 84

(Supersedes LO 10-3930-633-12, 29 MAY 1975)

TRACTOR, WHEELED, WAREHOUSE; GASOLINE, 4-WHEEL, PNEUMATIC TIRED; 4000 LB DBP (CLARK EQUIPMENT MODEL 2330237, ARMY MODEL MHE-228) (NSN 3930-00-347-6173)

Reference: TM 10-3930-633-12 and FEDERAL SUPPLY CATALOG C9100-IL.

Hard time intervals and the related man-hour times are based on normal operation. The man-hour time specified is the time you need to do all the services prescribed for a particular interval. Change the hard time interval if your lubricants are contaminated or if you are operating the equipment under adverse operating conditions, including longer-than-usual operating hours. The hard time interval may be extended during periods of low activity. If extended, adequate preservation precautions must be taken.

WARNING

Dry cleaning fluid is flammable. Do not use near a flame or excessive heat. Use only with adequate ventilation. Avoid prolonged breathing of vapors and minimize skin contact.

Clean parts or fittings with dry cleaning solvent (SD), Type II or equivalent. Dry before lubricating. Dotted arrow shafts indicate lubrication on both sides of equipment. A dotted circle indicates a drain below. Relubricate all items found contaminated after fording or washing.

The lowest level of maintenance authorized to lubricate a point is indicated by one of the following symbols as appropriate: Operator/Crew (C); and Organizational Maintenance (O).

Reporting errors and recommending improvements. You can help improve this manual. If you find any mistakes, or if you know of a way to improve the procedures, please let us know. Mail your letter or DA Form 2028 (Recommended Changes to Publications and Blank Forms) direct to: Commander, US Army Tank-Automotive Command, ATTN: DRSTA-MB, Warren, MI 48090. A reply will be furnished to you.

*The time specified is the time required to perform all services at the particular interval.

*TOTAL MAN-HOURS		*TOTAL MAN-HOURS	
INTERVAL	MAN-HOURS	INTERVAL	MAN-HOURS
10	0.8	500	2.3
100	1.5		
250	1.0		

TA 219945

LUBRICANT • INTERVAL

INTERVAL • LUBRICANT

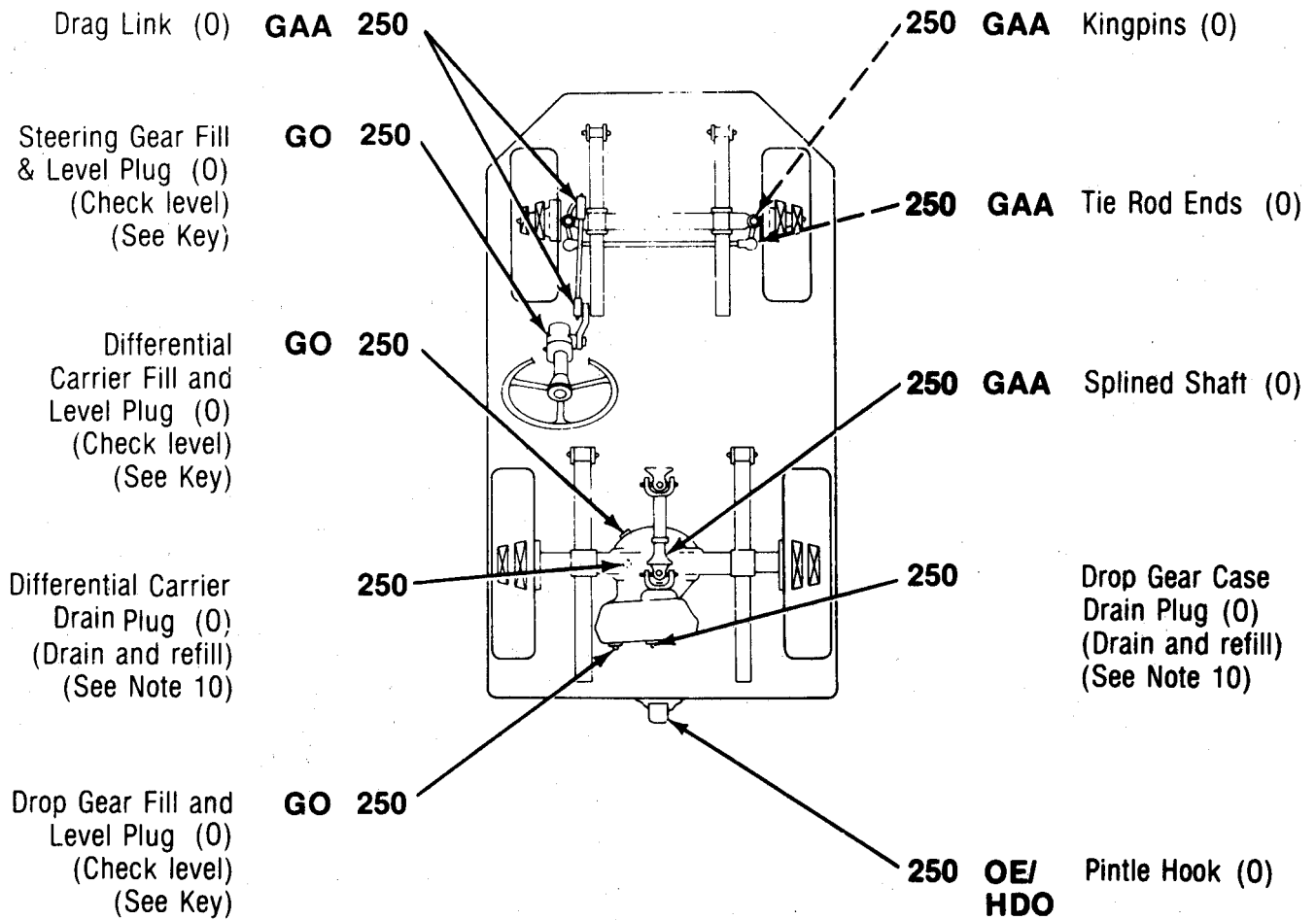

LUBRICANT • INTERVAL

INTERVAL • LUBRICANT

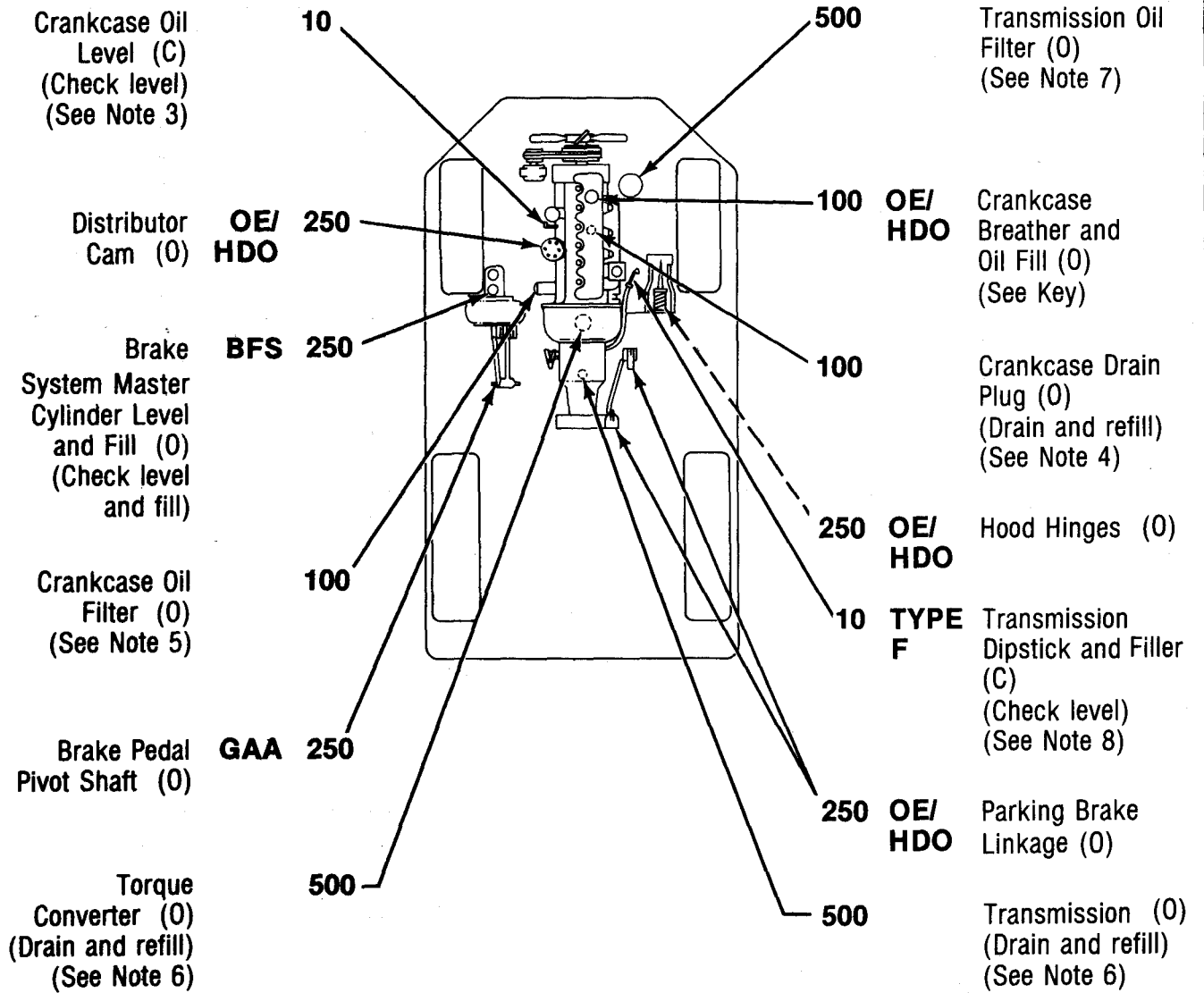

- * KEY -

LUBRICANTS	CAPACITY	EXPECTED TEMPERATURES			INTERVALS
		Above +15°F (Above -9°C)	+40° to -15°F (+4° to -26°C)	+40° to -65°F (+4° to -54°C)	
OE/ HDO - Lubricating Oil, Internal Combustion Engine, Tactical Service OEA - Lubricating Oil, Internal Combustion, Arctic - Crankcase w/Filter - Oil Can Points (See Note 2)	6 qts. (5.6 L)	OE/HDO 30	OE/HDO 10	OEA (See Note 1)	Intervals given are in hours of normal operation. For Arctic operation refer to FM 9-207
GO - Lubricating Oil, Gear Multipurpose - Differential Drop Gear	10 qts. (9.4 L)	GO 85W/140	GO 80W/90	GO 75W	
BFS - Brake Fluid, Silicone, Automotive - Brake System Master Cylinder	1 pt. (0.473 L)	ALL TEMPERATURES			
TYPE-F - Automatic Transmission Fluid - Transmission and Converter	11 qts. (10.4 L)	ALL TEMPERATURES			
GAA - Grease, Automotive and Artillery		ALL TEMPERATURES			

*See Note 10 for lubricant specification number.

NOTES:

1. FOR OPERATION OF EQUIPMENT IN PROTRACTED COLD TEMPERATURES BELOW -15°F (-26°C). Remove lubricants

prescribed in Key for temperatures above -15°F (-26°C). Relubricate with lubricants specified in Key for temperatures below

TA 219948

NOTES - CONTINUED:

-15°F (-26°C). If OEA lubricant is required to meet the temperature ranges prescribed in the Key, OEA lubricant is to be used in place of OE/HDO-10 lubricant for all temperature ranges where OE/HDO-10 is specified in the Key.

2. OIL CAN POINTS. Each 250 hours clean and lightly coat hood hinges, latch, pintle hook, carburetor and accelerator linkage and all exposed adjusting threads with OE/HDO.

3. ENGINE OIL LEVEL HOT OR COLD CHECK. Check engine, oil level should be at high mark on dipstick. Hot engine, oil level must be between high and low marks on dipstick (allow to set 5 minutes before checking).

4. ENGINE. Oil is to be changed each 100 hours. Drain when lubricant is warm.

5. ENGINE OIL FILTER. Each 100 hours, remove filter, clean filter mount, install new filter. After installing new filter, fill crankcase, operate engine for 5 minutes, check housing for leaks, check crankcase oil level and bring to "FULL" mark.

6. TRANSMISSION AND TORQUE CONVERTER. Check level each 10 hours with engine running at idle speed, oil at operating temperature and transmission in neutral. Maintain oil level at "FULL" mark. Change oil each 500 hours. Fill transmission to "LOW" mark. Run engine at idle speed to fill converter and lines. With engine running at idle speed, oil at operating temperature and transmission in neutral, add oil to bring oil level to "FULL" mark. Operate for 5 minutes and check for leaks.

7. TRANSMISSION OIL FILTER. Each 500 hours, remove filter, clean filter mount and install new filter and seal. Fill transmission to low mark. With engine running at idle speed, oil at operating temperature and transmission in neutral, add oil to bring oil level to "FULL" mark. Operate for 5 minutes and check filter for leaks.

8. AUTOMATIC TRANSMISSION. Transmission uses only Type "F" Automatic Transmission Fluid NSN 9150-00-843-1636 (1 Gal. can.)

9. DIFFERENTIAL/DROP GEARCASE. Change oil each 250 hours. After refill, operate for five minutes, check for leaks and bring oil level to fill and level plug opening:

10. LUBRICANTS. The following is a list of lubricants with military symbols and applicable specification numbers

OE/HDO	MIL-L-2104
GO	MIL-L-2105
GAA	MIL-G-10924
OEA	MIL-L-46167
BFS	MIL-B-46176
(SD), Type II	P-D-680
Type F	C1A2-19582-C

Copy of this Lubrication Order will remain with the equipment at all times, instructions contained herein are mandatory.

By order of the Secretary of the Army:

JOHN A. WICKHAM, JR.
General, United States Army
Chief of Staff

OFFICIAL:

ROBERT M. JOYCE
Major General, United States Army
The Adjutant General

DISTRIBUTION:

To be distributed in accordance with DA Form 12-256, Operator and Organizational maintenance requirements for Tractor.

